

Valve Features	
Maximum working pressure	6000psig
Working temperature	-18°C~121°C
Orifice	4.8mm
CV	0.75

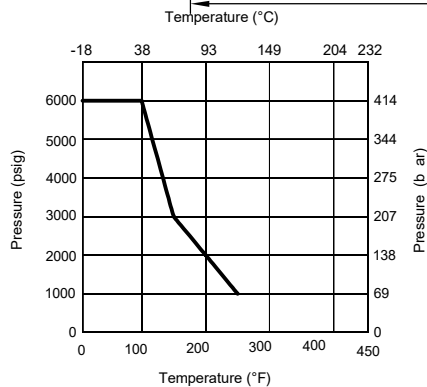
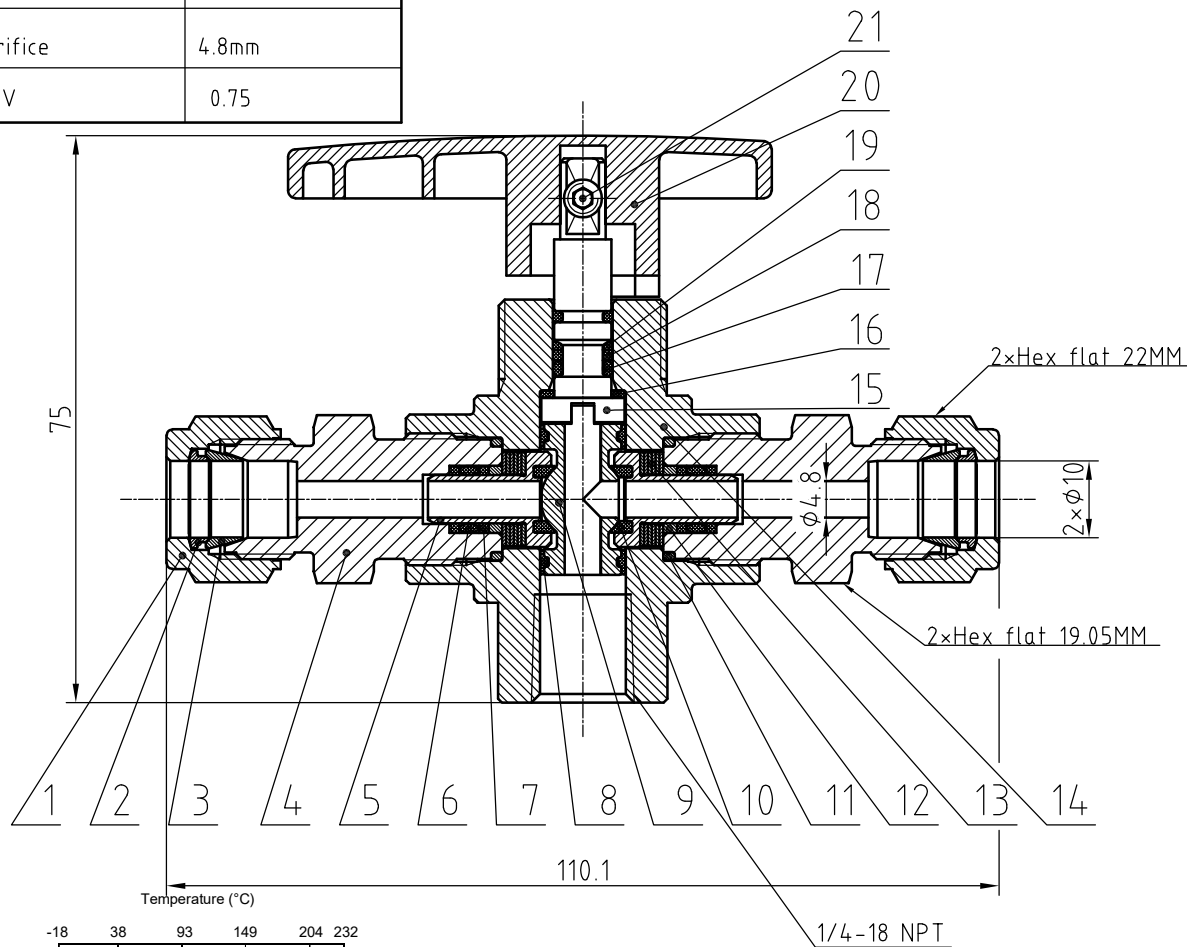

NOTE:Dimensions for reference only.

IDX	designation	materials
1	Nut	316L/A479
2	Rear Ferrules	316L/A479
3	Front Ferrules	316L/A479
4	End Connection	316L/A479
5	Seat Retainer	316L/A479
6	O-ring	FKM
7	Seat Retainer Backup Ring	PEEK
8	Trunnion Backup Ring	PEEK
9	Ball	316L/A479
10	O-ring	FKM
11	Seat	PCTFE
12	End Connection Seal	316L/A479
13	Seat Retainer Guide	316L/A479
14	<i>Packing Spring</i>	<i>S17700/A693</i>
15	Body	316L/A479
16	Stem	316L/A479
17	Panel Nut	316L/A479
18	Stem Washer	PEEK
19	O-ring	FKM
20	Handle	Nylon with SS insert
21	Set Screw	Galvanized carbon steel

Linear unit of size: mm		<i>Ball valve</i>		 ТЕХНОЛОГИИ РЕШЕНИЯ СЕРВИС	
signature	date				
design		versions	1	proportion	1:1
audit				Page 1/1	
ratify					
BVN7-2-3B-D-10M-PC-S					